

- CIRCUITO FRIGORIFERO ALTA PRESSIONE / HIGH PRESSURE REFRIGERANT CIRCUIT
- CIRCUITO FRIGORIFERO BASSA PRESSIONE / LOW PRESSURE REFRIGERANT CIRCUIT
- CIRCUITO IDRAULICO ACQUA CALDA / HYDRAULIC CIRCUIT WARM WATER
- CIRCUITO IDRAULICO ACQUA FREDDA / HYDRAULIC CIRCUIT COLD WATER
- LINEA DI RITORNO DELL'OLIO / OIL RETURN LINE (optional)

LEGENDA /
LEGEND

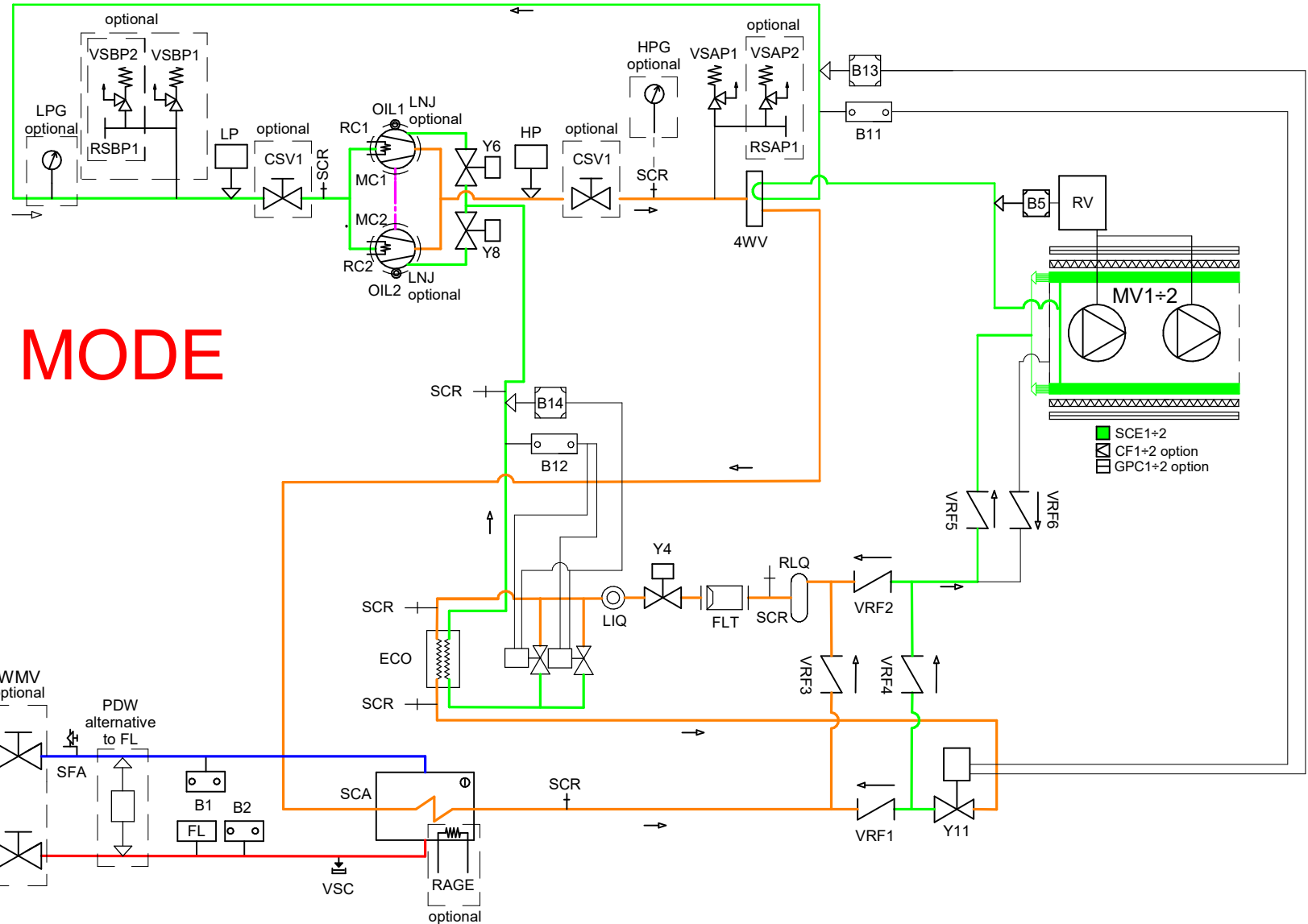

HEATING MODE

Scala-Scala	Data-Date 23/04/2018	Dis.to-Drawn G.M.	Ver.-Version	
Peso-Weight Kg	Materiali-Materials			
Denominazione-Denomination SBSHP.50-100				DIS.-DRAW N. SFI-SBSHP-100ST01
Particolare-Detail SCHEMA FRIGORIF./IDRAULICO HYDRAULIC/REFRIGERATING DIAGRAM				REVISIONE 00
1/4				PROGRAM. N.

- CIRCUITO FRIGORIFERO ALTA PRESSIONE / HIGH PRESSURE REFRIGERANT CIRCUIT
- CIRCUITO FRIGORIFERO BASSA PRESSIONE / LOW PRESSURE REFRIGERANT CIRCUIT
- CIRCUITO IDRAULICO ACQUA CALDA / HYDRAULIC CIRCUIT WARM WATER
- CIRCUITO IDRAULICO ACQUA FREDDA / HYDRAULIC CIRCUIT COLD WATER
- LINEA DI RITORNO DELL'OLIO / OIL RETURN LINE (optional)

LEGENDA /
LEGEND

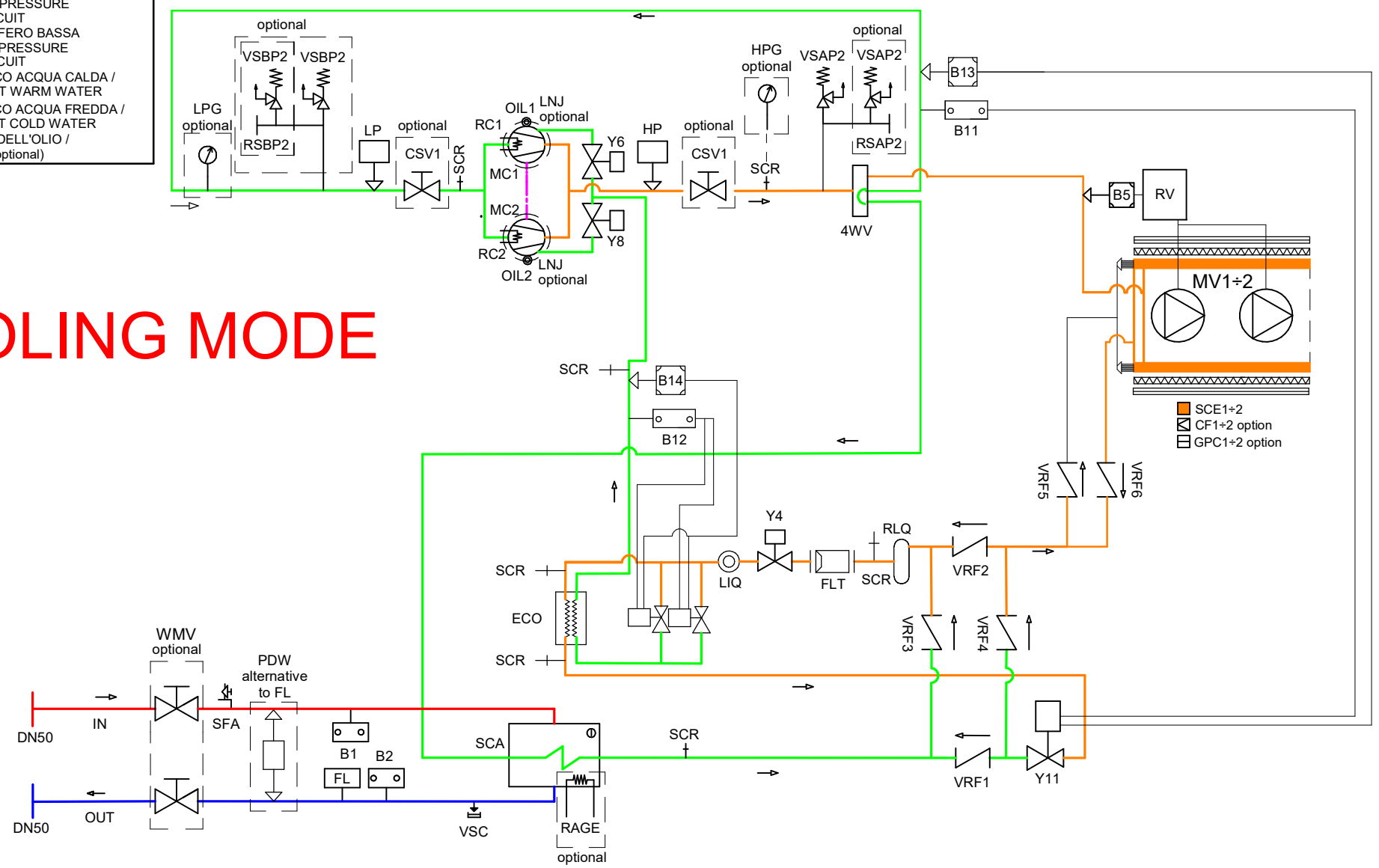

COOLING MODE



Scala-Scale	Data-Date 23/04/2018	Dis.to-Drawn G.M.	Ver.-Version	
Peso-Weight Kg	Materiali-Materials			
Denominazione-Denomination SBSHP.50-100				DIS.-DRAW N. SFI-SBSHP-100ST01
Particolare-Detail SCHEMA FRIGORIF./IDRAULICO HYDRAULIC/REFRIGERATING DIAGRAM				REVISIONE 00
2/4				PROGRAM. N.

CIRCUITO IDRICO / HYDRAULIC CIRCUIT-HEATING MODE

SIGLA	DESCRIZIONE	DESCRIPTION	MODELS	
FL	FLUSSOSTATO	FLOW SWITCH	std	
SFA	SFIATO ARIA	AIR VENT	manual for std (automatic with optional XV)	
B1	TEMPERATURA ACQUA INGRESSO	INLET TEMPERATURE SENSOR	std	
SCA	SCAMBIATORE DI CALORE AD ACQUA A PIASTRE	WATER BRASED PLATE HEAT EXCHANGER	std	
RAGE	RESISTENZA ANTIGELO SCAMBIATORE DI CALORE	ANTIFREEZE HEATER FOR THE BRASED PLATE	optional	
VSC	VALVOLA DI SCARICO ACQUA	DISCHARGE WATER VALVE	std	
B2	TEMPERATURA ACQUA USCITA	OUTLET TEMPERATURE SENSOR	std	
PDW	PRESSOSTATO DIFFERENZIALE	DIFFERENTIAL PRESSURE SWITCH	optional	
MWV	VALVOLE INTERCETTAZIONE ACQUA PER MANUTENZIONE	MAINTENANCE WATER VALVES	optional	



 CIRCUITO IDRAULICO ACQUA CALDA /
HYDRAULIC CIRCUIT WARM WATER
 CIRCUITO IDRAULICO ACQUA FREDDA /
HYDRAULIC CIRCUIT COLD WATER

LEGENDA /
LEGEND

Scala-Scale	Data-Date 23/04/2018	Dis.to-Drawn G.M.	Ver.-Version		
Peso-Weight Kg	Materiali-Materials			DIS.-DRAW N.	SFI-SBSHP-100ST01
Denominazione-Denomination SBSHP.50-100				REVISIONE	00
Particolare-Detail SCHEMA FRIGORIF./IDRAULICO HYDRAULIC/REFRIGERATING DIAGRAM				PROGRAM. N.	
3/4					

CIRCUITO FRIGORIFERO STANDARD / STANDARD REFRIGERATING CIRCUIT-HEATING MODE

SIGLA	DESCRIZIONE	DESCRIPTION	MODELS	
MC1+2	COMPRESSORE	COMPRESSOR	std	
RC1+2	RESISTENZA CARTER COMPRESSORE	COMPRESSOR CRANKCASE HEATER	std	
OIL1+2	SPIA DI LIVELLO OLIO	SIGHT GLASS FOR OIL LEVEL	std	
HP1	PRESSOSTATO ALTA PRESSIONE	HIGH PRESSURE SWITCH	std	
HPG1	MANOMETRO ALTA PRESSIONE	HIGH PRESSURE GAUGE	optional	
VSAP1	VALVOLA SICUREZZA ALTA PRESSIONE	HIGH PRESSURE SAFETY VALVE	std	
4WV	VALVOLA A QUATTRO VIE PER L'INVERSIONE DI CICLO	FOUR WAY VALVE FOR THE REVERSION OF THE CYCLE	std	
SCE	SCAMBIATORE DI CALORE AD ARIA (EVAPORATORE)	AIR HEAT EXCHANGER (EVAPORATOR)	std	
GPC	GRIGLIA PROTEZIONE EVAPORATORE	EVAPORATOR GRID PROTECTION	optional	
CF	FILTRO ARIA EVAPORATORE	AIR EVAPORATOR FILTER	optional	
MV1+2	MOTOVENTILATORE ASSIALE	AXIAL FAN MOTOR	std AC fans	
B5	TRASDUTTORE ALTA PRESSIONE	HIGH PRESSURE TRASDUCER	std	
RV	REGOLATORE DI VELOCITA' VENTILATORI	FAN SPEED REGULATOR	std	
VRF1+6	VALVOLA DI NON RITORNO FREON	NO RETURN FREON VALVE	std	
RLQ	RICEVITORE DI LIQUIDO	LIQUID RECEIVER	std	
SCR	VALVOLA DI CARICO SCHRADER	CHARGE VALVE (SCHRADER)	std	
FLT	FILTRO DISIDRATATORE CIRCUITO REFRIGERANTE	DEHYDRATING FILTER FOR LIQUID LINE	std	
LIQ	SPIA DI FLUSSO / INDICATORE DI LIQUIDO	LIQUID INDICATOR / SIGHT GLASS FOR LIQUID LINE	std	
Y11	VALVOLA DI ESPANSIONE ELETTRONICA	ELECTRIC EXPANSION VALVE	std	
SCA	SCAMBIATORE DI CALORE AD ACQUA (CONDENSATORE A PIASTRE)	WATER HEAT EXCHANGER (BRASED PLATE CONDENSER)	std	
LPG1	MANOMETRO BASSA PRESSIONE	LOW PRESSURE GAUGE	optional	
LP1	PRESSOSTATO DI BASSA PRESSIONE	LOW PRESSURE SWITCH	std	
Y4	VALVOLA SOLENOIDE LIQUIDO CIRCUITO	LOW PRESSURE SWITCH	std	

	CIRCUITO FRIGORIFERO ALTA PRESSIONE / HIGH PRESSURE REFRIGERANT CIRCUIT
	CIRCUITO FRIGORIFERO BASSA PRESSIONE / LOW PRESSURE REFRIGERANT CIRCUIT
	LINEA DEI EQUALIZZAZIONE DELL'OLIO / EQUALISATION LINE OF OIL

LEGENDA /
LEGEND

Scala-Scale	Data-Date 23/04/2018	Dis.to-Drawn G.M.	Ver.-Version	
Peso-Weight Kg	Materiali-Materials			
Denominazione-Denomination SBSHP.50-100				DIS.-DRAW N. SFI-SBSHP-100ST01
Particolare-Detail SCHEMA FRIGORIF./IDRAULICO HYDRAULIC/REFRIGERATING DIAGRAM				REVISIONE 00
4/4				PROGRAM. N.