

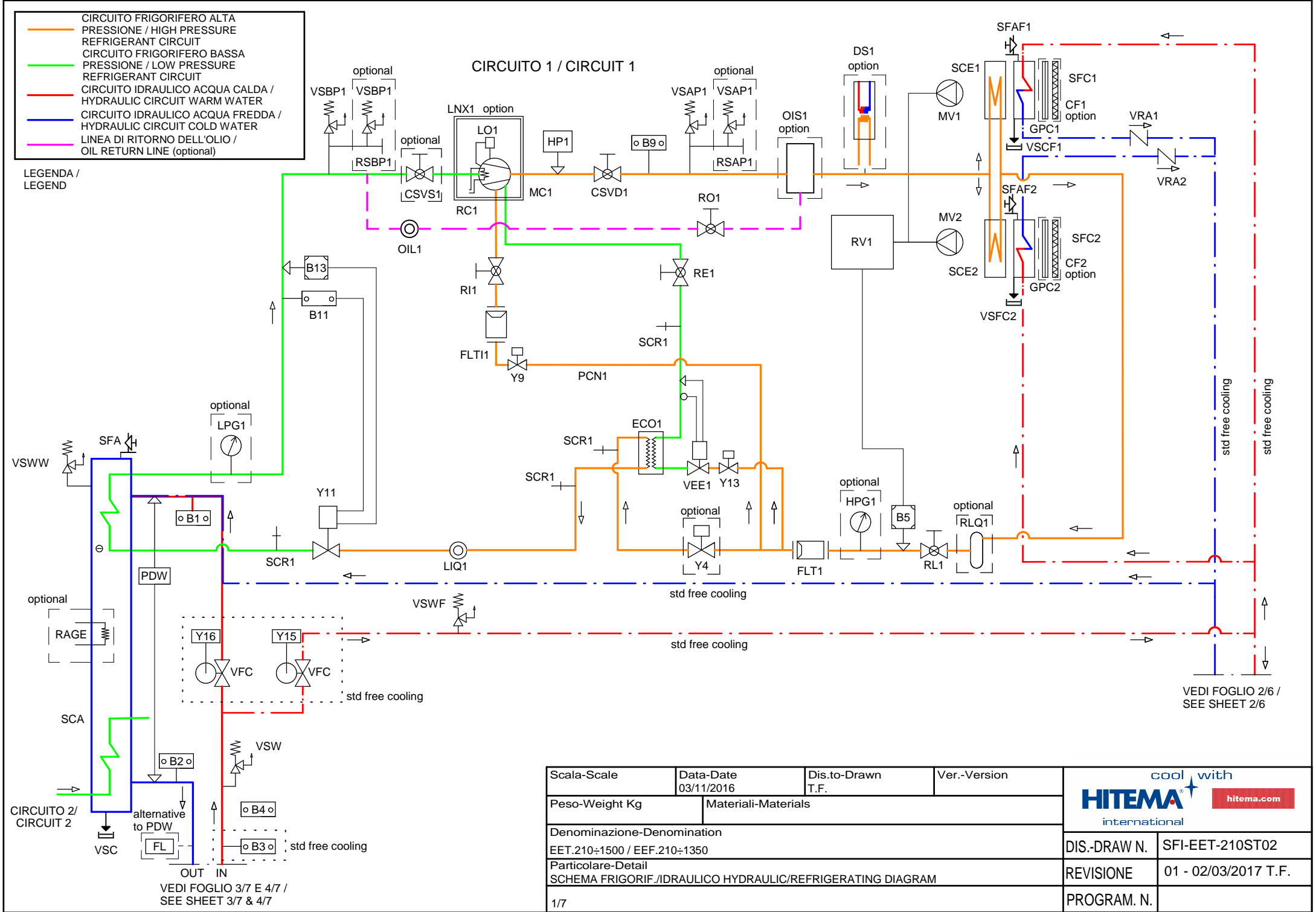

- CIRCUITO FRIGORIFERO ALTA PRESSIONE / HIGH PRESSURE REFRIGERANT CIRCUIT
- CIRCUITO FRIGORIFERO BASSA PRESSIONE / LOW PRESSURE REFRIGERANT CIRCUIT
- CIRCUITO IDRAULICO ACQUA CALDA / HYDRAULIC CIRCUIT WARM WATER
- CIRCUITO IDRAULICO ACQUA FREDDA / HYDRAULIC CIRCUIT COLD WATER
- LINEA DI RITORNO DELL'OLIO / OIL RETURN LINE (optional)

LEGENDA / LEGEND



VEDI FOGLIO 3/7 E 4/7 / SEE SHEET 3/7 & 4/7

VEDI FOGLIO 2/6 / SEE SHEET 2/6

Scala-Scale	Data-Date 03/11/2016	Dis.to-Drawn T.F.	Ver.-Version	
Peso-Weight Kg	Materiali-Materials			
Denominazione-Denomination EET.210÷1500 / EEF.210÷1350				DIS.-DRAW N. SFI-EET-210ST02
Particolare-Detail SCHEMA FRIGORIF./IDRAULICO HYDRAULIC/REFRIGERATING DIAGRAM				REVISIONE 01 - 02/03/2017 T.F.
1/7				PROGRAM. N.

CIRCUITO 2 / CIRCUIT 2

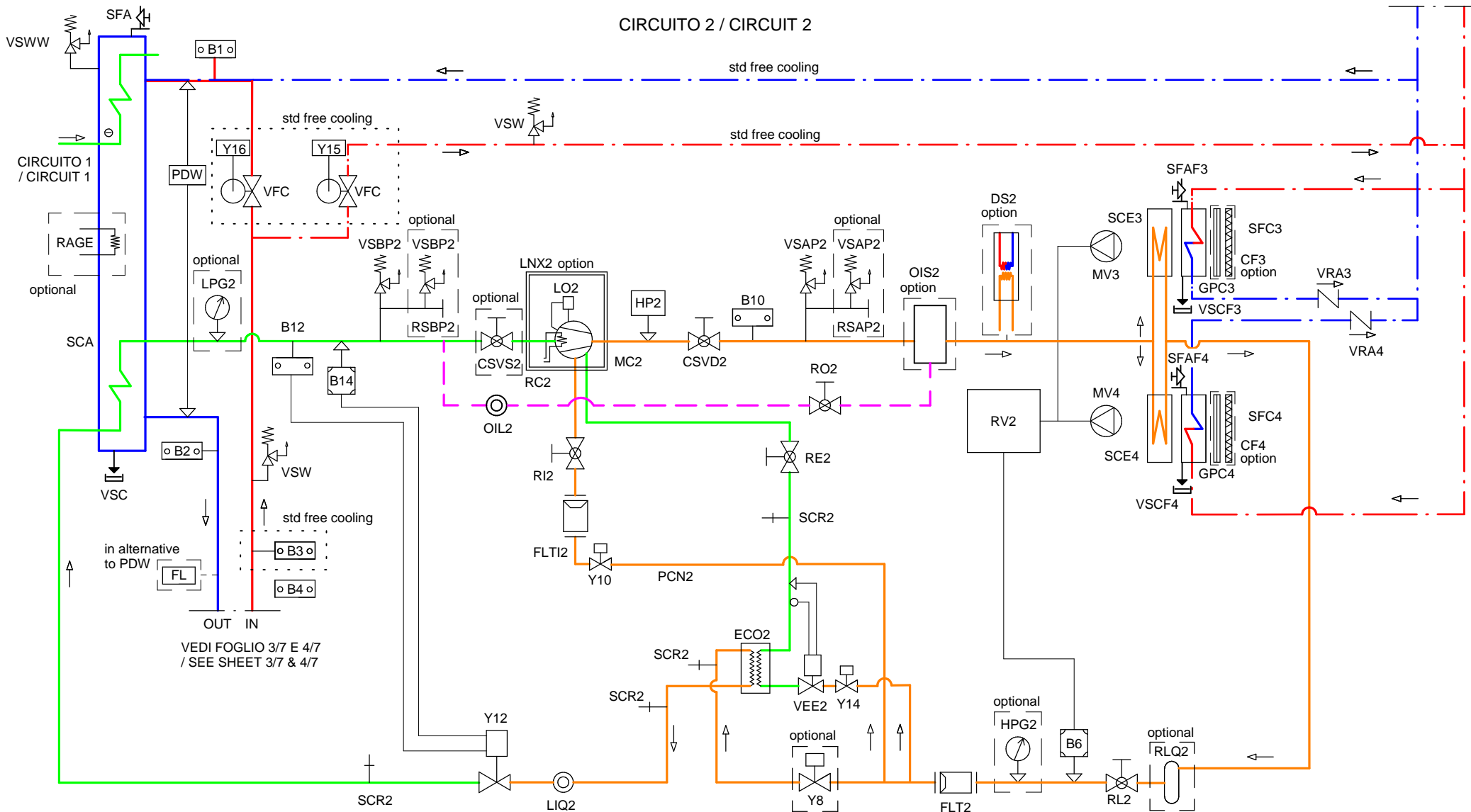

- CIRCUITO FRIGORIFERO ALTA PRESSIONE / HIGH PRESSURE REFRIGERANT CIRCUIT
- CIRCUITO FRIGORIFERO BASSA PRESSIONE / LOW PRESSURE REFRIGERANT CIRCUIT
- CIRCUITO IDRAULICO ACQUA CALDA / HYDRAULIC CIRCUIT WARM WATER
- CIRCUITO IDRAULICO ACQUA FREDDA / HYDRAULIC CIRCUIT COLD WATER
- - - LINEA DI RITORNO DELL'OLIO / OIL RETURN LINE (optional)

LEGGENDA /
LEGEND

Scala-Scale	Data-Date 03/11/2016	Dis.to-Drawn T.F.	Ver.-Version
Peso-Weight Kg		Materiali-Materials	
Denominazione-Denomination EET.210÷1500 / EEF.210÷1350			
Particolare-Detail SCHEMA FRIGORIF./IDRAULICO HYDRAULIC/REFRIGERATING DIAGRAM			
DIS.-DRAW N.		SFI-EET-210ST02	
REVISIONE		01 - 02/03/2017 T.F.	
PROGRAM. N.			



— CIRCUITO IDRAULICO ACQUA CALDA / HYDRAULIC CIRCUIT WARM WATER
— CIRCUITO IDRAULICO ACQUA FREDDA / HYDRAULIC CIRCUIT COLD WATER

LEGENDA /
 LEGEND

CASO A / CASE A (ONLY ON REQUEST) :

CON SERBATOIO - CON POMPA - CON POMPA DI RICIRCOLO INTERNO /
 WITH TANK - WITH PUMP - WITH INTERNAL RECIRCULATING PUMP

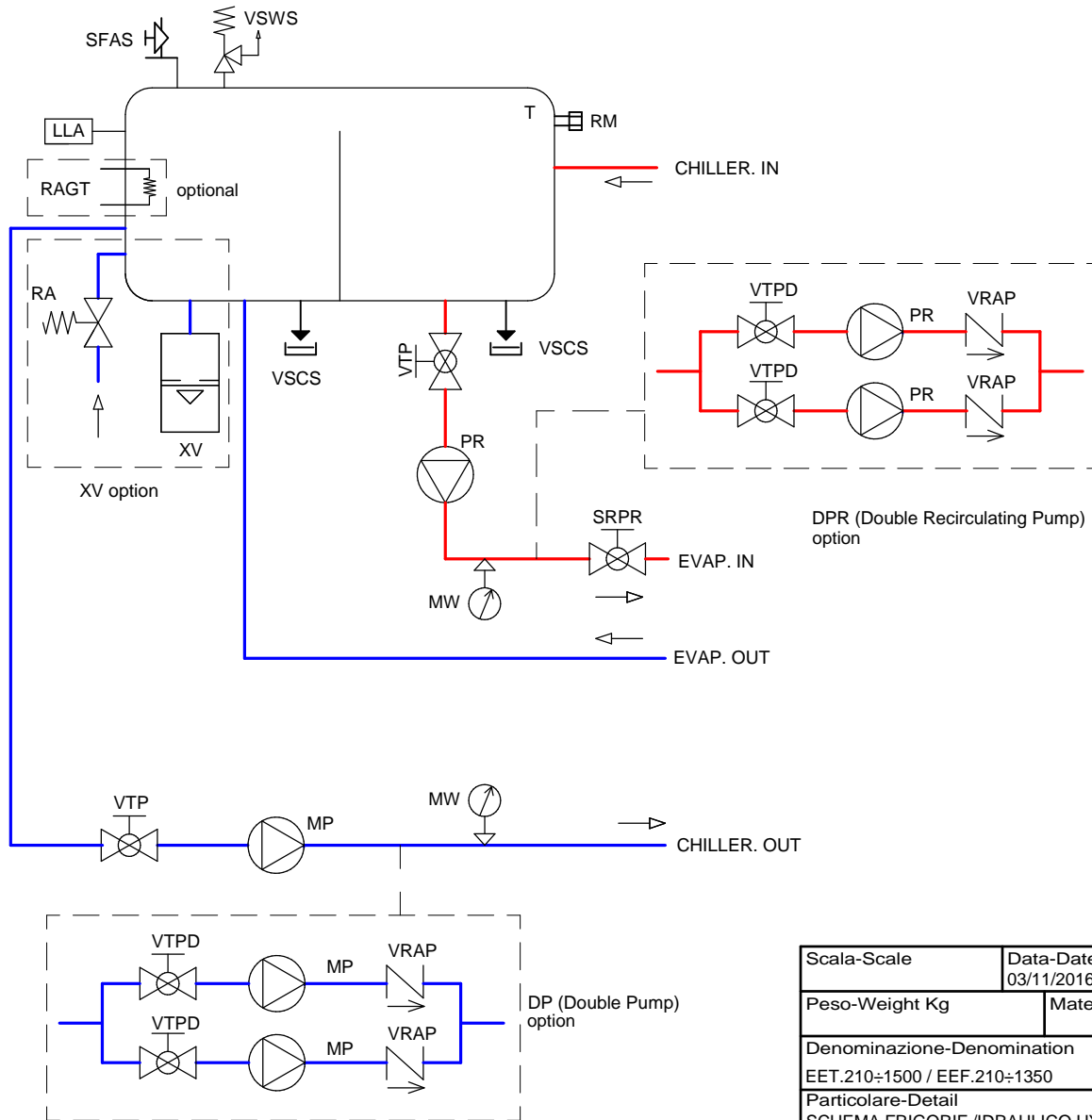

CASO B / CASE B :

CON SERBATOIO - CON POMPA /
 WITH TANK - WITH PUMP

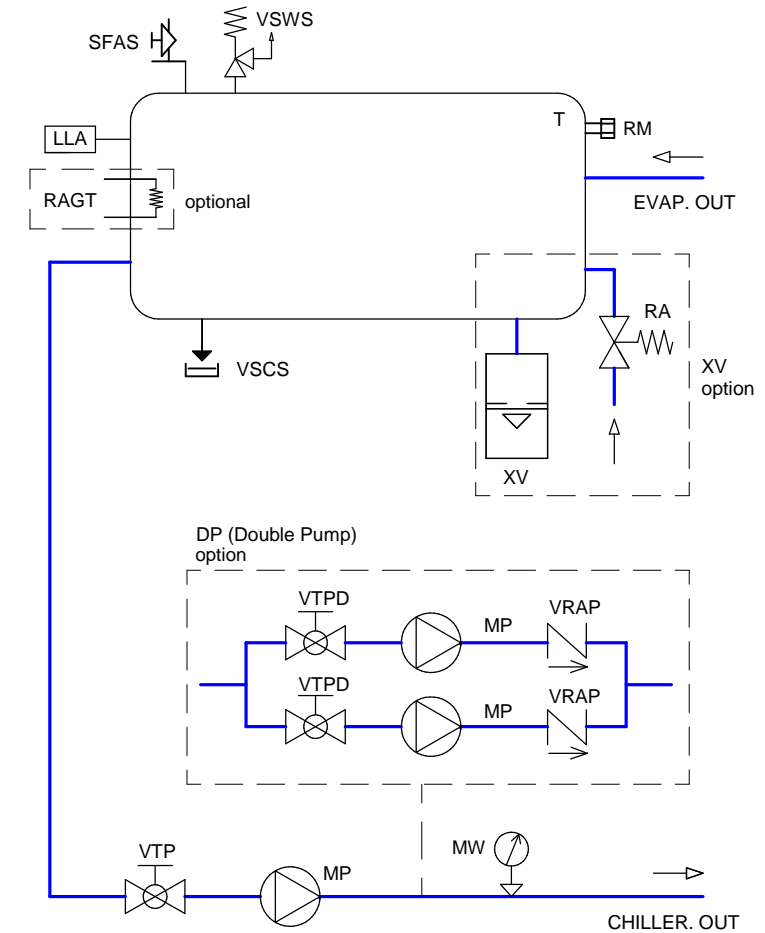

Scala-Scale	Data-Date 03/11/2016	Dis.to-Drawn T.F.	Ver.-Version	
Peso-Weight Kg	Materiali-Materials			
Denominazione-Denomination EET.210÷1500 / EEF.210÷1350				DIS-DRAW N. SFI-EET-210ST02
Particolare-Detail SCHEMA FRIGORIF./IDRAULICO HYDRAULIC/REFRIGERATING DIAGRAM				REVISIONE 01 - 02/03/2017 T.F.
3/7				PROGRAM. N.

- CIRCUITO IDRAULICO ACQUA CALDA / HYDRAULIC CIRCUIT WARM WATER
- CIRCUITO IDRAULICO ACQUA FREDDA / HYDRAULIC CIRCUIT COLD WATER

LEGENDA /
LEGEND

CASO C / CASE C :

SENZA SERBATOIO - CON POMPA /
WITHOUT TANK - WITH PUMP

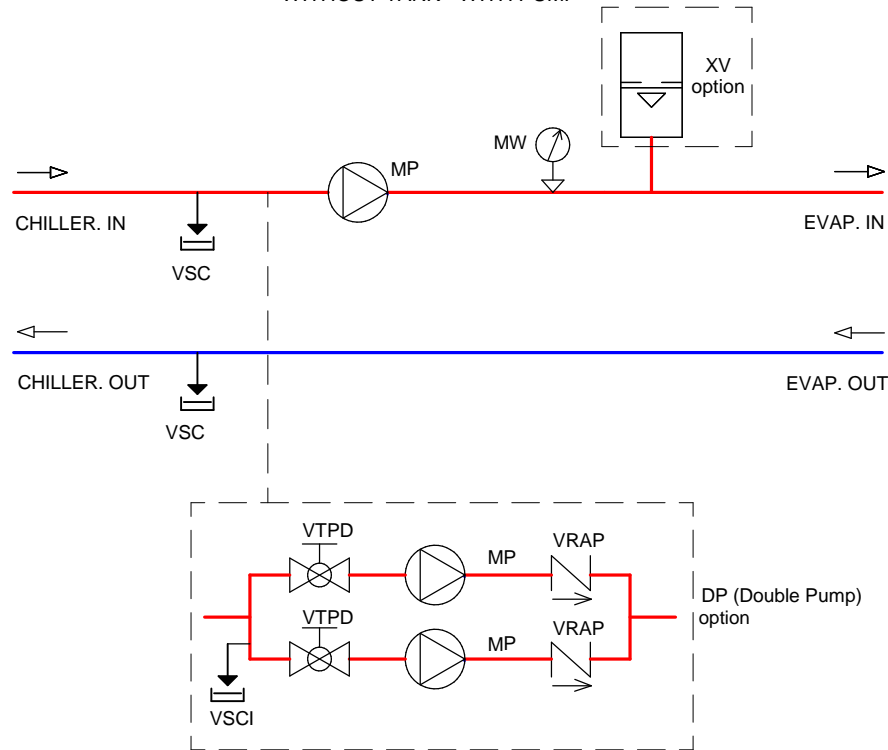

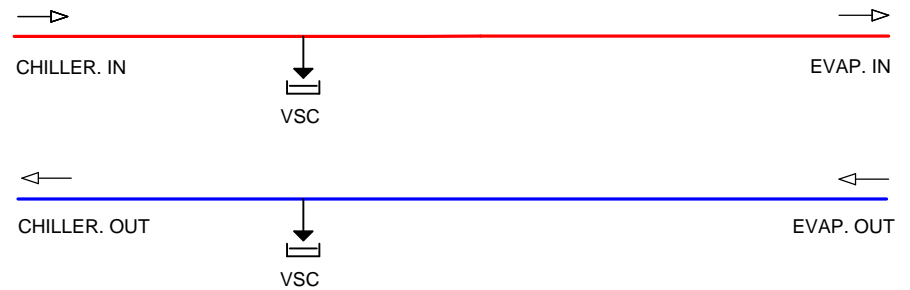

CASO D / CASE D (STANDARD CONFIGURATION) :

SENZA SERBATOIO - SENZA POMPA /
WITHOUT TANK - WITHOUT PUMP



Scala-Scale	Data-Date 03/11/2016	Dis.to-Drawn T.F.	Ver.-Version	
Peso-Weight Kg	Materiali-Materials			
Denominazione-Denomination EET.210÷1500 / EEF.210÷1350				DIS.-DRAW N. SFI-EET-210ST02
Particolare-Detail SCHEMA FRIGORIF./IDRAULICO HYDRAULIC/REFRIGERATING DIAGRAM				REVISIONE 01 - 02/03/2017 T.F.
4/7				PROGRAM. N.



CIRCUITO IDRICO / HYDRAULIC CIRCUIT			
SIGLA / SIGN	DESCRIZIONE	DESCRIPTION	NOTE
VSC	VALVOLA DI SCARICO ACQUA	WATER DISCHARGE VALVE	std
VSW	VALVOLA DI SICUREZZA ACQUA	WATER RELIEF VALVE	std
B1	SENSORE TEMPERATURA ACQUA INGRESSO EVAPORATORE	EVAPORATOR INLET WATER TEMPERATURE SENSOR	std
SCA	SCAMBIATORE DI CALORE AD ACQUA (EVAPORATORE A FASCIO TUBIERO)	WATER HEAT EXCHANGER (SHELL & TUBE EVAPORATOR)	std
SFA	SFIATO DELL'ARIA MANUALE EVAPORATORE	EVAPORATOR MANUAL AIR VENT	std
VSC	VALVOLA DI SCARICO ACQUA EVAPORATORE	EVAPORATOR WATER DISCHARGE VALVE	std
VSWW	VALVOLA DI SICUREZZA EVAPORATORE	EVAPORATOR RELIEF VALVE	std
RAGE	RESISTENZA ANTIGELO EVAPORATORE	EVAPORATOR ANTIFREEZE HEATER	optional
PDW	PRESSOSTATO DIFFERENZIALE	DIFFERENTIAL PRESSURE SWITCH	std, flow switch (FL) in alternative
B2	SENSORE TEMPERATURA ACQUA USCITA EVAPORATORE	EVAPORATOR OUTLET WATER TEMPERATURE SENSOR	std
T	SERBATOIO	TANK	optional
SFAS	SFIATO DELL'ARIA MANUALE SERBATOIO	TANK MANUAL AIR VENT	optional (automatic with optional XV)
RM	TAPPO DI RIEMPIMENTO MANUALE	MANUAL FILLING CAP	optional (included in the optional T)
VSCS	VALVOLA DI SCARICO ACQUA SERBATOIO	TANK WATER DISCHARGE VALVE	optional (included in the optional T)
VSWs	VALVOLA DI SICUREZZA SERBATOIO	TANK RELIEF VALVE	optional (included in the optional T)
LLA	SENSORE DI LIVELLO ELETTRONICO	ELECTRONIC LOW LEVEL ALLARM	optional (included in the optional T)
RAGT	RESISTENZA ANTIGELO SERBATOIO	TANK ANTIFREEZE HEATER	optional
XV	VASO DI ESPANSIONE	EXPANSION VESSEL	optional (included in the optional XV)
RA	RIEMPIMENTO AUTOMATICO CON RITEGNO E FILTRO INCORPORATI	AUTOMATIC FEEDER WITH CHECK VALVE AND FILTER INCORPORATED	optional (included in the optional XV)
VTP	VALVOLA DI INTERCETTAZIONE TRA VASCA E POMPA	BALL VALVE BETWEEN TANK AND PUMP	optional (included in the opt. WP, PH, DP, DPH)
MP	POMPA DI PROCESSO, SINGOLA O DOPPIA	SINGLE OR DOUBLE PROCESS PUMP	optional WP, PH or DP, DPH
PR	POMPA DI RICIRCOLO, SINGOLA O DOPPIA	SINGLE OR DOUBLE RECIRCULATING PUMP	optional on request
VRAP	VALVOLA DI NON RITORNO DOPPIA POMPA	DOUBLE PUMP CHECK VALVE	optional (included in the optional DP, DPH)
SRPR	VALVOLA DI INTERCETTAZIONE POMPA DI RICIRCOLO	RECIRCULATING PUMP BALL VALVE	optional on request (included with optional PR)
MW	MANOMETRO ACQUA	WATER PRESSURE GAUGE	optional (included in the opt. WP, PH, DP, DPH)
VSC	VALVOLA DI SCARICO ACQUA	WATER DISCHARGE VALVE	std
	CIRCUITO DEL FREE COOLING (SERIE EEF, ITF)	FREE COOLING CIRCUIT (EEF, ITF SERIES)	
B3	SENSORE TEMPERATURA ACQUA INGRESSO FREE COOLING	FREE COOLING INLET WATER TEMPERATURE SENSOR	std free cooling
VFC	VALVOLA A 2 VIE	2-WAYS VALVE	std free cooling
Y15÷16	SERVOCOMANDO VALVOLA A DUE VIE	2-WAYS VALVE SERVOCONTROL	std free cooling
VSWF	VALVOLA DI SICUREZZA FREE COOLING	FREE COOLING RELIEF VALVE	std free cooling
SFC1÷4	SCAMBIATORE DI CALORE ARIA-ACQUA (FREE COOLING)	AIR-WATER HEAT EXCHANGER (FREE COOLING)	std free cooling
SFAF1÷4	SFIATO DELL'ARIA MANUALE FREE COOLING	FREE COOLING MANUAL AIR VENT	std free cooling
VSCF1÷4	VALVOLA DI SCARICO ACQUA FREE COOLING	FREE COOLING WATER DISCHARGE VALVE	std free cooling
VRA1÷4	VALVOLA DI NON RITORNO FREE COOLING	FREE COOLING CHECK VALVE	std free cooling

	CIRCUITO IDRAULICO ACQUA CALDA / HYDRAULIC CIRCUIT WARM WATER
	CIRCUITO IDRAULICO ACQUA FREDDA / HYDRAULIC CIRCUIT COLD WATER

LEGENDA /
LEGEND

Scala-Scale	Data-Date 03/11/2016	Dis.to-Drawn T.F.	Ver.-Version	 cool with HITEMA international hitema.com
Peso-Weight Kg	Materiali-Materials			
Denominazione-Denomination EET.210÷1500 / EEF.210÷1350				DIS-DRAW N. SFI-EET-210ST02
Particolare-Detail SCHEMA FRIGORIF./IDRAULICO HYDRAULIC/REFRIGERATING DIAGRAM				REVISIONE 01 - 02/03/2017 T.F.
5/7				PROGRAM. N.



CIRCUITO FRIGORIFERO / REFRIGERATING CIRCUIT (TAB 1/2)			
SIGLA / SIGN	DESCRIZIONE	DESCRIPTION	NOTE
MC1÷2	COMPRESSORE	COMPRESSOR	std
LO1÷2	SENSORE LIVELLO MINIMO OLIO COMPRESSORE	COMPRESSOR OIL LEVEL SENSOR	std
RC1÷2	RESISTENZA CARTER COMPRESSORE	COMPRESSOR CRANKCASE HEATER	std
LN1÷2	BOX INSONORIZZAZIONE COMPRESSORI	NOISE INSULATING COMPRESSOR BOX	optional
HP1÷2	PRESSOSTATO ALTA PRESSIONE	HIGH PRESSURE SWITCH	std
CSVD1÷2	VALVOLA DI INTERCETTAZIONE MANDATA COMPRESSORE	DISCHARGE LINE COMPRESSOR SHUT OFF VALVE	std
B9÷10	SENSORE TEMPERATURA MANDATA COMPRESSORE	DISCHARGE COMPRESSOR TEMPERATURE SENSOR	std
VSAP1÷2	VALVOLA DI SICUREZZA ALTA PRESSIONE	HIGH PRESSURE RELIEF VALVE	std
RSAP1÷2	VALVOLA DI COMMUTAZIONE ALTA PRESSIONE	HIGH PRESSURE CHANGEOVER VALVE	optional on request of double relief valve
OIS1÷2	SEPARATORE D'OLIO	OIL SEPARATOR	optional on request
DS1÷2	DESURRISCALDATORE O RECUPERATORE TOTALE DI CALORE	DESUPERHEATER OR TOTAL HEAT RECOVERY	optional PDS or TDS
SCE1÷4	SCAMBIATORE DI CALORE AD ARIA (CONDENSATORE)	AIR HEAT EXCHANGER (CONDENSER)	std
GPC1÷4	GRIGLIA METALLICA PROTEZIONE CONDENSATORE	METALLIC GUARD FOR CONDENSER	optional
CF1÷4	FILTRO ARIA CONDENSATORE IN ALLUMINIO	CONDENSER AIR ALUMINUM FILTER	optional
MV1÷n	MOTOVENTILATORE ASSIALE	AXIAL FAN	std AC fans (optional EC fans)
RV1÷2	REGOLATORE DI VELOCITA' VENTILATORI	ELECTRONIC FAN SPEED CONTROL	std
RLQ1÷2	RICEVITORE DI LIQUIDO	LIQUID RECEIVER	optional
RL1÷2	RUBINETTO LINEA DEL LIQUIDO	LIQUID LINE BALL VALVE	std
B5÷6	TRASDUTTORE ALTA PRESSIONE	HIGH PRESSURE TRASDUCER	std
HPG1÷2	MANOMETRO ALTA PRESSIONE	HIGH PRESSURE GAUGE	optional
FLT1÷2	FILTRO DISIDRATATORE	DEHYDRATING FILTER	std
Y4, Y8	VALVOLA SOLENOIDE LINEA DEL LIQUIDO	LIQUID LINE SOLENOID VALVE	optional
SCR1÷2	VALVOLA DI CARICO SCHRADER	CHARGE VALVE (SCHRADER)	std
ECO1÷2	ECONOMIZZATORE	ECONOMIZER	std
LIQ1÷2	SPIA DI FLUSSO	SIGHT GLASS	std
Y11÷12	VALVOLA DI ESPANSIONE ELETTRONICA	ELECTRONIC EXPANSION VALVE	std
SCR1÷2	VALVOLA DI CARICO SCHRADER	CHARGE VALVE (SCHRADER)	std
SCA	SCAMBIATORE DI CALORE AD ACQUA (EVAPORATORE A FASCIO TUBIERO)	WATER HEAT EXCHANGER (SHELL & TUBE EVAPORATOR)	std
LPG1÷2	MANOMETRO BASSA PRESSIONE	LOW PRESSURE GAUGE	optional
B11÷12	SENSORE TEMPERATURA ASPIRAZIONE COMPRESSORE	SUCTION COMPRESSOR TEMPERATURE SENSOR	std
B13÷14	TRASDUTTORE BASSA PRESSIONE PER LA VALVOLA DI ESPANSIONE	LOW PRESSURE TRASDUCER FOR THE EXPANSION VALVE	std
VSBP1÷2	VALVOLA DI SICUREZZA BASSA PRESSIONE	LOW PRESSURE RELIEF VALVE	std
RSBP1÷2	VALVOLA DI COMMUTAZIONE BASSA PRESSIONE	LOW PRESSURE CHANGEOVER VALVE	optional on request of double relief valve
CSVS1÷2	VALVOLA DI INTERCETTAZIONE ASPIRAZIONE COMPRESSORE	SUCTION LINE COMPRESSOR SHUT OFF VALVE	optional

	CIRCUITO FRIGORIFERO ALTA PRESSIONE / HIGH PRESSURE REFRIGERANT CIRCUIT
	CIRCUITO FRIGORIFERO BASSA PRESSIONE / LOW PRESSURE REFRIGERANT CIRCUIT
	LINEA DI RITORNO DELL'OLIO / OIL RETURN LINE

LEGENDA /
LEGEND

Scala-Scale	Data-Date 03/11/2016	Dis.to-Drawn T.F.	Ver.-Version	 cool with HITEMA international hitema.com	
Peso-Weight Kg	Materiali-Materials				
Denominazione-Denomination EET.210÷1500 / EEF.210÷1350				DIS.-DRAW N.	SFI-EET-210ST02
Particolare-Detail SCHEMA FRIGORIF./IDRAULICO HYDRAULIC/REFRIGERATING DIAGRAM				REVISIONE	01 - 02/03/2017 T.F.
6/7				PROGRAM. N.	

CIRCUITO FRIGORIFERO / REFRIGERATING CIRCUIT (TAB 2/2)			
SIGLA / SIGN	DESCRIZIONE	DESCRIPTION	NOTE
	LINEA DI RITORNO DELL'OLIO (OIL)	OIL RETURN LINE (OIL)	
OIS1÷2	SEPARATORE D'OLIO	OIL SEPARATOR	optional on request
RO1÷2	RUBINETTO LINEA DI RITORNO DELL'OLIO	OIL RETURN LINE BALL VALVE	optional on request (included with optional OIS)
OIL1÷2	SPIA DI FLUSSO OLIO	OIL SIGHT GLASS	optional on request (included with optional OIS)
	LINEA ECONOMIZZATORE (ECO)	ECONOMIZER LINE (ECO)	
Y13÷14	VALVOLA SOLENOIDE ECONOMIZZATORE	ECONOMIZER SOLENOID VALVE	std
VEE1÷2	VALVOLA DI ESPANSIONE TERMOSTATICA ECONOMIZZATORE	ECONOMIZER THERMOSTATIC EXPANSION VALVE	std
ECO1÷2	ECONOMIZZATORE	ECONOMIZER	std
SCR1÷2	VALVOLA DI CARICO SCHRADER	CHARGE VALVE (SCHRADER)	std
RE1÷2	RUBINETTO LINEA ECONOMIZZATORE	ECONOMIZER LINE BALL VALVE	std
	LINEA INIEZIONE DI LIQUIDO AL COMPRESSORE (PCN)	COMPRESSOR LIQUID INJECTION LINE (PCN)	
Y9÷10	VALVOLA SOLENOIDE LINEA INIEZIONE DI LIQUIDO	LIQUID INJECTION LINE SOLENOID VALVE	std
FLT1÷2	FILTRO DISIDRATATORE	DEHYDRATING FILTER	std
RI1÷2	RUBINETTO LINEA INIEZIONE DI LIQUIDO	LIQUID INJECTION LINE BALL VALVE	std

	CIRCUITO FRIGORIFERO ALTA PRESSIONE / HIGH PRESSURE REFRIGERANT CIRCUIT
	CIRCUITO FRIGORIFERO BASSA PRESSIONE / LOW PRESSURE REFRIGERANT CIRCUIT
	LINEA DI RITORNO DELL'OLIO / OIL RETURN LINE

LEGENDA /
LEGEND

ALTRO / OTHER			
SIGLA / SIGN	DESCRIZIONE	DESCRIPTION	NOTE
B4	SENSORE TEMPERATURA AMBIENTE	AMBIENT TEMPERATURE SENSOR	std

Scala-Scale	Data-Date 03/11/2016	Dis.to-Drawn T.F.	Ver.-Version	
Peso-Weight Kg	Materiali-Materials			
Denominazione-Denomination EET.210÷1500 / EEF.210÷1350				DIS.-DRAW N. SFI-EET-210ST02
Particolare-Detail SCHEMA FRIGORIF./IDRAULICO HYDRAULIC/REFRIGERATING DIAGRAM				REVISIONE 01 - 02/03/2017 T.F.
7/7				PROGRAM. N.