

- CIRCUITO FRIGORIFERO ALTA PRESSIONE / HIGH PRESSURE REFRIGERANT CIRCUIT
- CIRCUITO FRIGORIFERO BASSA PRESSIONE / LOW PRESSURE REFRIGERANT CIRCUIT
- CIRCUITO IDRAULICO ACQUA CALDA / HYDRAULIC CIRCUIT WARM WATER
- CIRCUITO IDRAULICO ACQUA FREDDA / HYDRAULIC CIRCUIT COLD WATER
- - - LINEA DEI EQUALIZZAZIONE DELL'OLIO / EQUALISATION LINE OF OIL

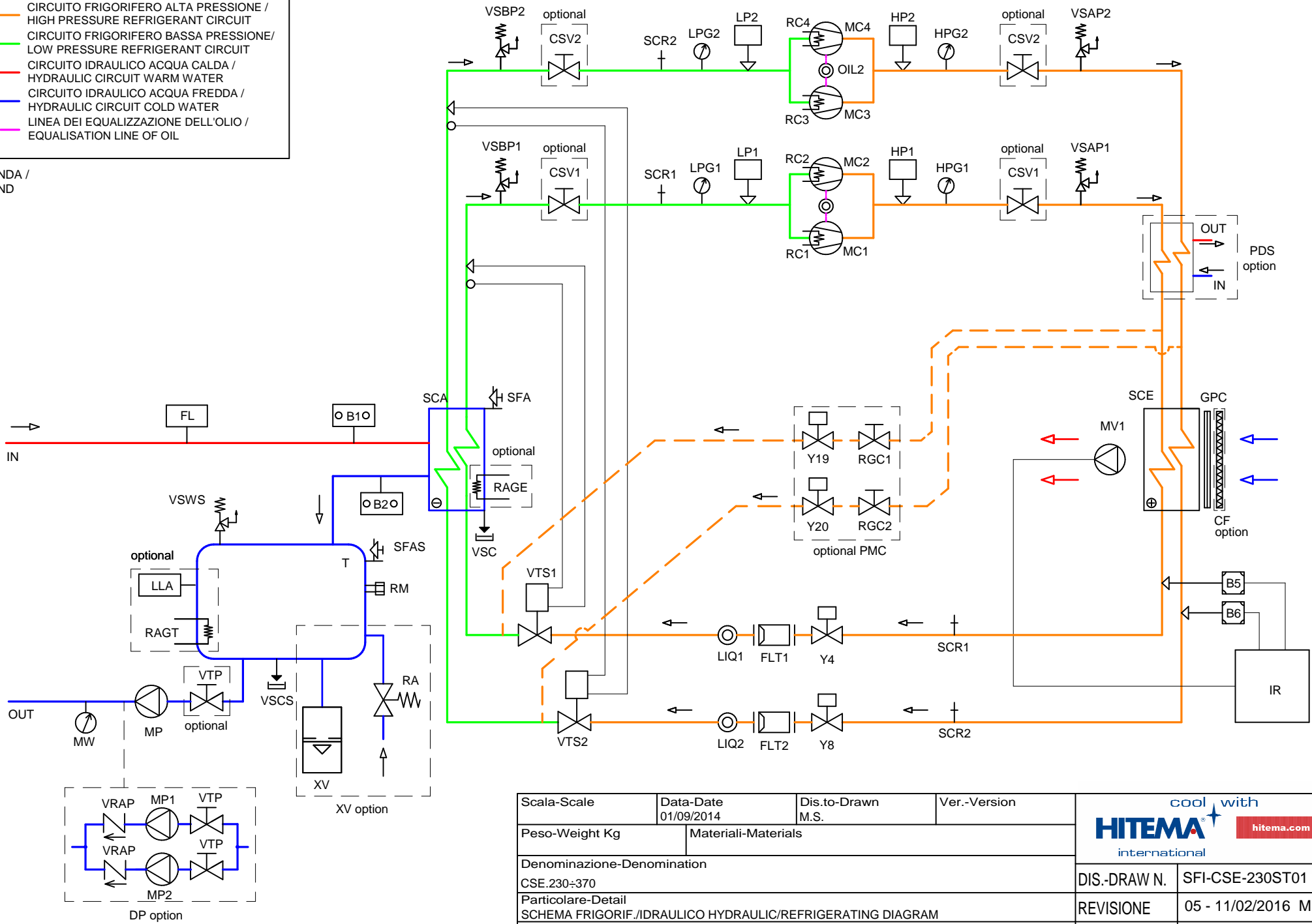

LEGENDA /
LEGEND



Scala-Scale	Data-Date 01/09/2014	Dis.to-Drawn M.S.	Ver.-Version	
Peso-Weight Kg	Materiali-Materials			
Denominazione-Denomination CSE.230-370				DIS-DRAW N. SFI-CSE-230ST01
Particolare-Detail SCHEMA FRIGORIF./IDRAULICO HYDRAULIC/REFRIGERATING DIAGRAM				REVISIONE 05 - 11/02/2016 M.S.
FOGLIO/SHEET 1/3				PROGRAM. N.

CIRCUITO IDRICO / HYDRAULIC CIRCUIT

SIGLA	DESCRIZIONE	DESCRIPTION	MODELS
FL	FLUSSOSTATO	FLOW SWITCH	std
B1	TEMPERATURA ACQUA INGRESSO EVAPORATORE	EVAPORATOR INLET TEMPERATURE SENSOR	std
SCA	SCAMBIATORE DI CALORE AD ACQUA (EVAPORATORE A FASCIO)	WATER HEAT EXCHANGER (SHELL & TUBE EVAPORATOR)	std
VSC	VALVOLA DI SCARICO ACQUA	DISCHARGE WATER VALVE	std
SFA	SFIATO ARIA MANUALE	MANUAL AIR VENT	std
RAGE	RESISTENZA ANTIGELO EVAPORATORE	EVAPORATOR ANTIFREEZE HEATER	optional
B2	TEMPERATURA ACQUA USCITA EVAPORATORE	EVAPORATOR OUTLET TEMPERATURE SENSOR	std
T	SERBATOIO DI ACCUMULO	TANK	std
RM	TAPPO DI RIEMPIMENTO MANUALE	MANUAL FILLING CAP	std
VSWS	VALVOLA SICUREZZA SERBATOIO	TANK SAFETY VALVE	std
VSCS	VALVOLA DI SCARICO ACQUA DEL SERBATOIO	DISCHARGE WATER VALVE FOR TANK	std
SFAS	SFIATO ARIA SERBATOIO	AIR VENT FOR TANK	manual for std (automatic with XV option)
LLA	ALLARME BASSO LIVELLO ACQUA	ELECTRIC FLOAT LOW LEVEL ALARM	optional
RAGT	RESISTENZA ANTIGELO VASCA	ANTIFREEZE HEATER INERTIAL TANK	optional
XV	VASO DI ESPANSIONE	EXPANSION VESSEL	optional (included in the XV option)
RA	RIEMPIMENTO AUTOMATICO CON VALVOLA DI RITEGNO E FILTRO INCLUSO	AUTOMATIC FEEDER WITH CHECK VALVE AND FILTER INCORPORATED	optional (included in the XV option)
MP	ELETTROPOMPA DI PROCESSO	PROCESSING PUMP	std
MW	MANOMETRO ACQUA	WATER PRESSURE GAUGE	std
VTP	VALVOLA DI INTERCETTAZIONE TRA VASCA E POMPA	SHUT OFF VALVE BETWEEN TANK AND PUMP	optional
MP1-MP2	ELETTROPOMPA DI PROCESSO	PROCESSING PUMP	optional (included in the DP option)
VRAP	VALVOLA DI NON RITORNO ACQUA	NO RETURN WATER VALVE	optional (included in the DP option)



	CIRCUITO IDRAULICO ACQUA CALDA / HYDRAULIC CIRCUIT WARM WATER
	CIRCUITO IDRAULICO ACQUA FREDDA / HYDRAULIC CIRCUIT COLD WATER

LEGENDA /
LEGEND

Scala-Scale	Data-Date 01/09/2014	Dis.to-Drawn M.S.	Ver.-Version		
Peso-Weight Kg	Materiali-Materials				
Denominazione-Denomination CSE.230-370				DIS.-DRAW N.	SFI-CSE-230ST01
Particolare-Detail SCHEMA FRIGORIF./IDRAULICO HYDRAULIC/REFRIGERATING DIAGRAM				REVISIONE	05 - 11/02/2016 M.S.
FOGLIO/SHEET 2/3				PROGRAM. N.	

CIRCUITO FRIGORIFERO STANDARD / STANDARD REFRIGERATING CIRCUIT

SIGLA	DESCRIZIONE	DESCRIPTION	MODELS
MC1÷MC4	COMPRESSORE	COMPRESSOR	std
RC1÷RC4	RESISTENZA CARTER COMPRESSORE	COMPRESSOR CRANKCASE HEATER	std
OIL1÷2	SPIA DI FLUSSO LINEA EQUALIZZAZIONE OLIO	SIGHT GLASS FOR EQUALISATION LINE OF OIL	std
HP1÷2	PRESSOSTATO ALTA PRESSIONE	HIGH PRESSURE SWITCH	std
HPG1÷2	MANOMETRO ALTA PRESSIONE	HIGH PRESSURE GAUGE	std
VSAP1÷2	VALVOLA DI SICUREZZA LINEA DI ALTA PRESSIONE	HIGH PRESSURE SAEFTY VALVE	std
CSV1÷2	VALVOLA DI INTERCETTAZIONE COMPRESSORI	COMPRESSORS SHUT OFF VALVE	optional
PDS	DESURRISCALDATORE PARZIALE	PARTIAL DESUPERHEATER	optional
SCE	SCAMBIATORE DI CALORE AD ARIA (CONDENSATORE)	AIR HEAT EXCHANGER (CONDENSER)	std
GPC	GRIGLIA PROTEZIONE CONDENSATORE	CONDENSER GRID PROTECTION	std
CF	FILTRO ARIA CONDENSATORE	AIR CONDENSER FILTER	optional
MV1	MOTOVENTILATORE CENTRIFUGO	CENTRIFUGAL FAN MOTOR	std
B5÷6	TRASDUTTORE ALTA PRESSIONE	HIGH PRESSURE TRASDUCER	std
IR	INVERTER VENTILATORI	INVERTER FAN SPEED REGULATOR	std
SCR1÷2	VALVOLA DI CARICO SCHRADER	CHARGE VALVE (SCHRADER)	std
Y4÷8	VALVOLA SOLENOIDE LIQUIDO CIRCUITO	SOLENOID-VALVE FOR LIQUID LINE	std
FLT1÷2	FILTRO DISIDRATATORE CIRCUITO REFRIGERANTE	DEHYDRATING FILTER FOR LIQUID LINE	std
LIQ1÷2	SPIA DI FLUSSO / INDICATORE DI LIQUIDO	LIQUID INDICATOR / SIGHT GLASS FOR LIQUID LINE	std
VTS1÷2	VALVOLA DI ESPANSIONE TERMOSTATICA	THERMOSTATIC EXPANSION VALVE	std
SCA	SCAMBIATORE DI CALORE AD ACQUA (EVAPORATORE A FASCIO)	WATER HEAT EXCHANGER (SHELL & TUBE EVAPORATOR)	std
VSBP1÷2	VALVOLA DI SICUREZZA LINEA DI BASSA PRESSIONE	LOW PRESSURE SAEFTY VALVE	std
CSV1÷2	VALVOLA DI INTERCETTAZIONE COMPRESSORI	COMPRESSORS SHUT OFF VALVE	optional
SCR1÷2	VALVOLA DI CARICO SCHRADER	CHARGE VALVE (SCHRADER)	std
LPG1÷2	MANOMETRO BASSA PRESSIONE	LOW PRESSURE GAUGE	std
LP1÷2	PRESSOSTATO DI BASSA PRESSIONE	LOW PRESSURE SWITCH	std
PMC	BYPASS GAS CALDO	HOT GAS BYPASS	optional
RGC1÷2	RUBINETTO GAS CALDO	HOT GAS SHUT OFF VALVE	optional (included in the PMC option)
Y19-Y20	ELETTROVALVOLA BYPASS GAS CALDO	HOT GAS BYPASS VALVE (SOLENOIDE VALVE)	optional (included in the PMC option)

	CIRCUITO FRIGORIFERO ALTA PRESSIONE / HIGH PRESSURE REFRIGERANT CIRCUIT
	CIRCUITO FRIGORIFERO BASSA PRESSIONE / LOW PRESSURE REFRIGERANT CIRCUIT
	LINEA DEI EQUALIZZAZIONE DELL'OLIO / EQUALISATION LINE OF OIL

LEGENDA /
LEGEND

Scala-Scale	Data-Date 01/09/2014	Dis.to-Drawn M.S.	Ver.-Version		
Peso-Weight Kg	Materiali-Materials				
Denominazione-Denomination CSE.230÷370				DIS.-DRAW N.	SFI-CSE-230ST01
Particolare-Detail SCHEMA FRIGORIF./IDRAULICO HYDRAULIC/REFRIGERATING DIAGRAM				REVISIONE	05 - 11/02/2016 M.S.
FOGLIO/SHEET 3/3				PROGRAM. N.	