

- CIRCUITO FRIGORIFERO ALTA PRESSIONE / HIGH PRESSURE REFRIGERANT CIRCUIT
- CIRCUITO FRIGORIFERO BASSA PRESSIONE / LOW PRESSURE REFRIGERANT CIRCUIT
- CIRCUITO IDRAULICO ACQUA CALDA / HYDRAULIC CIRCUIT WARM WATER
- CIRCUITO IDRAULICO ACQUA FREDDA / HYDRAULIC CIRCUIT COLD WATER
- - - LINEA DEI EQUALIZZAZIONE DELL'OLIO / EQUALISATION LINE OF OIL

LEGENDA /
LEGEND

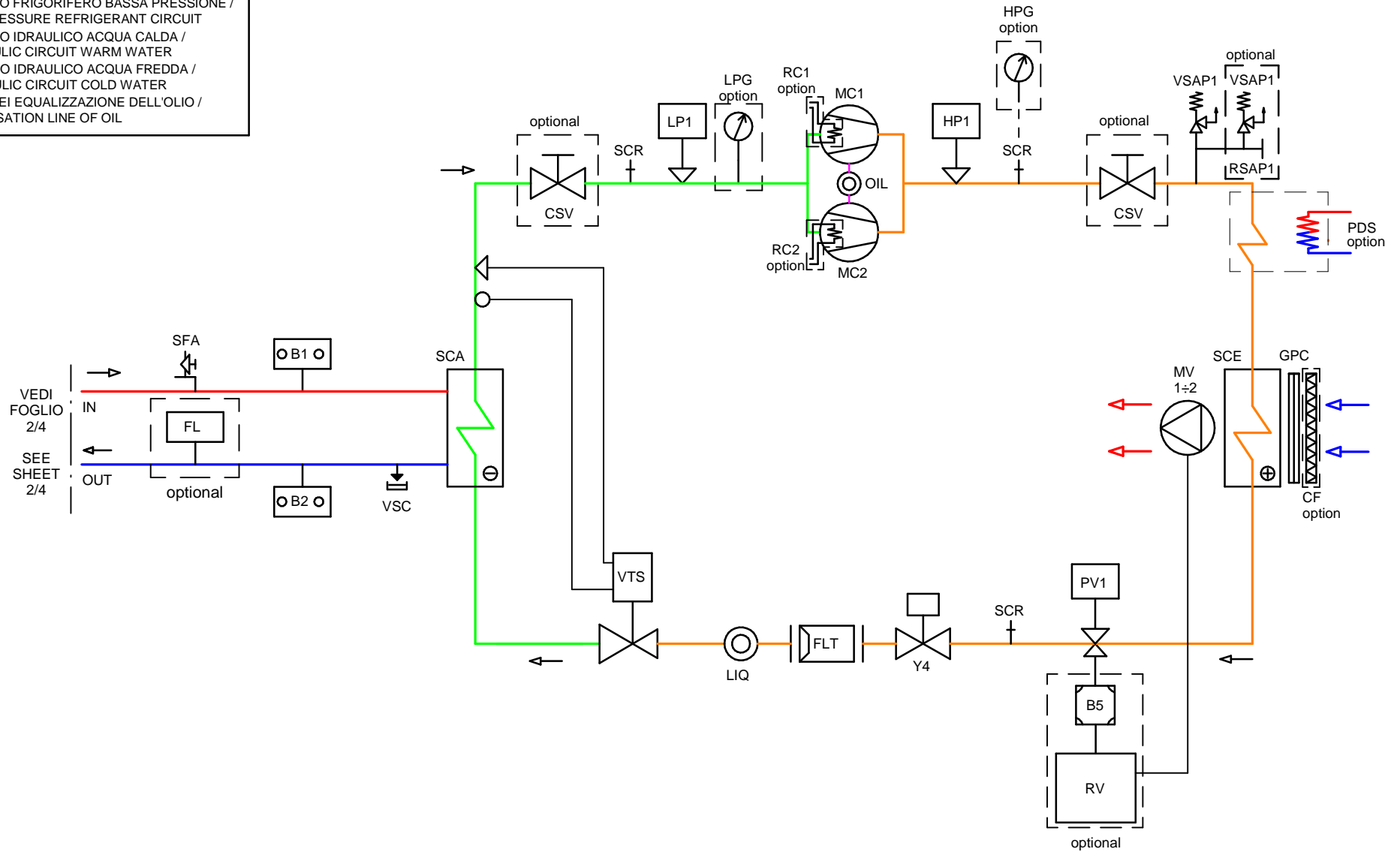

Scala-Scale	Data-Date	Dis.to-Drawn	Ver.-Version	
	09/10/2013	A.F.		
Peso-Weight Kg	Materiali-Materials			DIS-DRAW N.
Denominazione-Denomination				SFI-CFT-061ST01
CFT.061÷100				REVISIONE
Particolare-Detail				02 - 30/09/2016 T.F.
SCHEMA FRIGORIF./IDRAULICO HYDRAULIC/REFRIGERATING DIAGRAM				PROGRAM. N.
FOGLIO/SHEET 1/4				

— CIRCUITO IDRAULICO ACQUA CALDA /
 HYDRAULIC CIRCUIT WARM WATER
— CIRCUITO IDRAULICO ACQUA FREDDA /
 HYDRAULIC CIRCUIT COLD WATER

LEGENDA /
 LEGEND

CON SERBATOIO - CON POMPA /
 WITH TANK - WITH PUMP

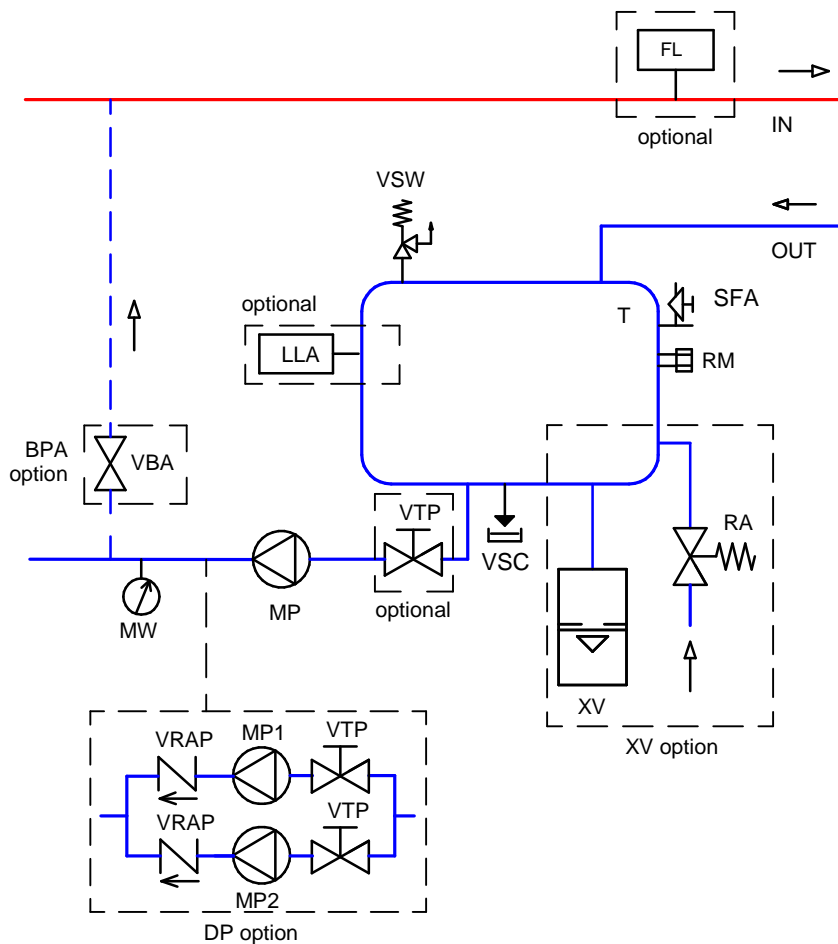

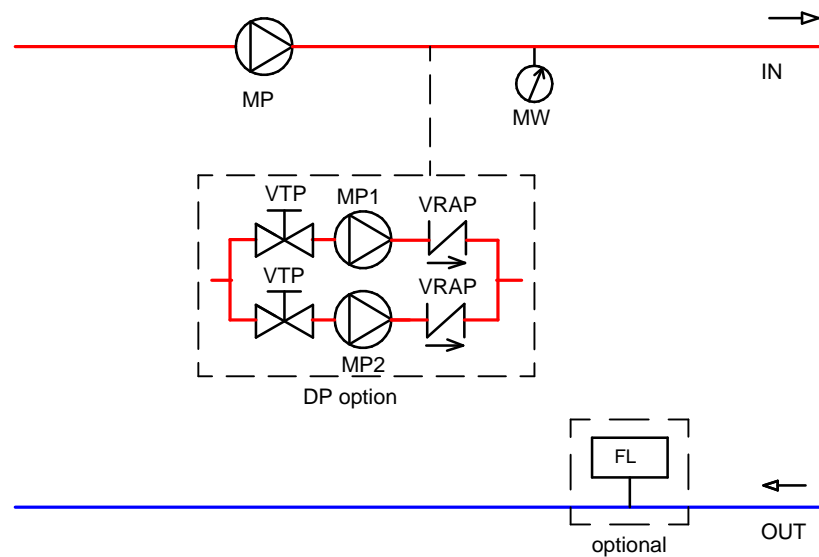

SENZA SERBATOIO - CON POMPA /
 WITHOUT TANK - WITH PUMP



Scala-Scale	Data-Date 09/10/2013	Dis.to-Drawn A.F.	Ver.-Version	
Peso-Weight Kg	Materiali-Materials			
Denominazione-Denomination CFT.061÷100				DIS-DRAW N. SFI-CFT-061ST01
Particolare-Detail SCHEMA FRIGORIF./IDRAULICO HYDRAULIC/REFRIGERATING DIAGRAM				REVISIONE 02 - 30/09/2016 T.F.
FOGLIO/SHEET 2/4				PROGRAM. N.



CIRCUITO IDRAULICO / HYDRAULIC CIRCUIT				
SIGLA / SIGN	DESCRIZIONE	DESCRIPTION	NOTE	
MP	ELETTROPOMPA DI PROCESSO	PROCESSING PUMP	optional	
MW	MANOMETRO ACQUA	WATER PRESSURE GAUGE	optional	
SCA	SCAMBIATORE DI CALORE AD ACQUA (EVAPORATORE A PIASTRE)	WATER HEAT EXCHANGER (BRAZED PLATE EVAPORATOR)	std	
SFA	SFIATO DELL'ARIA	AIR VENT	std	
B1	SENSORE TEMPERATURA ACQUA INGRESSO EVAPORATORE	EVAPORATOR INLET WATER TEMPERATURE SENSOR	std	
VSC	VALVOLA DI SCARICO ACQUA	WATER DISCHARGE VALVE	std	
B2	SENSORE TEMPERATURA ACQUA USCITA EVAPORATORE	EVAPORATOR OUTLET WATER TEMPERATURE SENSOR	std	
FL	FLUSSOSTATO	FLOW SWITCH	optional	
T	SERBATOIO DI ACCUMULO	TANK	optional	
RM	TAPPO DI RIEMPIMENTO MANUALE	MANUAL FILLING CAP	optional(included in the T option)	
SFAS	SFIATO ARIA	AIR VENT	optional(included in the T option)	
VSWS	VALVOLA SICUREZZA ACQUA	SAFETY WATER VALVE	optional(included in the T option)	
VSCS	VALVOLA DI SCARICO ACQUA	DISCHARGE WATER VALVE	optional(included in the T option)	
LLA	ALLARME BASSO LIVELLO ACQUA	ELECTRIC FLOAT LOW LEVEL ALARM	optional	
XV	VASO DI ESPANSIONE	RIEMPIMENTO AUTOMATICO CON VALVOLA DI RITEGNO E FILTRO	optional (included in the XV option)	
RA	RIEMPIMENTO AUTOMATICO CON VALVOLA DI RITEGNO E FILTRO	AUTOMATIC FEEDER WITH CHECK VALVE AND FILTER INCORPORATED	optional (included in the XV option)	
BPA	BYPASS AUTOMATICO	AUTOMATIC BYPASS	optional	
VBA	VALVOLA DI BYPASS AUTOMATICO	AUTOMATIC BYPASS VALVE	optional (included in the BPA option)	
VTP	VALVOLA DI INTERCETTAZIONE TRA VASCA E POMPA	SHUT OFF VALVE BETWEEN TANK AND PUMP	optional	
MP1-MP2	ELETTROPOMPA DI PROCESSO	PROCESSING PUMP	optional	
VRAP	VALVOLA DI NON RITORNO ACQUA	NO RETURN WATER VALVE	optional	

	CIRCUITO IDRAULICO ACQUA CALDA / HYDRAULIC CIRCUIT WARM WATER
	CIRCUITO IDRAULICO ACQUA FREDDA / HYDRAULIC CIRCUIT COLD WATER

LEGENDA /
LEGEND

Scala-Scale	Data-Date 09/10/2013	Dis.to-Drawn A.F.	Ver.-Version		
Peso-Weight Kg	Materiali-Materials				
Denominazione-Denomination CFT.061÷100				DIS.-DRAW N.	SFI-CFT-061ST01
Particolare-Detail SCHEMA FRIGORIF./IDRAULICO HYDRAULIC/REFRIGERATING DIAGRAM				REVISIONE	02 - 30/09/2016 T.F.
FOGLIO/SHEET 3/4				PROGRAM. N.	

CIRCUITO FRIGORIFERO / REFRIGERATING CIRCUIT			
SIGLA / SIGN	DESCRIZIONE	DESCRIPTION	NOTE
MC1	COMPRESSORE	COMPRESSOR	std
RC1	RESISTENZA CARTER COMPRESSORE	COMPRESSOR CRANKCASE HEATER	optional (std for mod 090÷100)
OIL	IL SPIA DI FLUSSO LINEA EQUALIZZAZIONE OLIO	SIGHT GLASS FOR EQUALISATION LINE OF OIL	std
HP1	PRESSOSTATO ALTA PRESSIONE	HIGH PRESSURE SWITCH	std
HPG	MANOMETRO ALTA PRESSIONE	HIGH PRESSURE GAUGE	optional
VSAP	VALVOLA DI SICUREZZA ALTA PRESSIONE	HIGH PRESSURE SAFETY VALVE	std
	VALVOLA DI COMMUTAZIONE LINEA ALTA PRESSIONE	HIGH PRESSURE CHANGEOVER VALVE	optional
PDS	RECUPERATORE DI CALORE PARZIALE O TOTALE	PARTIAL OR TOTAL HEAT RECOVER	optional
SCE	SCAMBIATORE DI CALORE AD ARIA (CONDENSATORE)	AIR HEAT EXCHANGER (CONDENSER)	std
GPC	GRIGLIA PROTEZIONE CONDENSATORE	CONDENSER GRID PROTECTION	std
CF	FILTRO ARIA CONDENSATORE	AIR CONDENSER FILTER	optional
MV1÷2	MOTOVENTILATORE ASSIALE	AXIAL FAN MOTOR	std
PV1	PRESSOSTATO VENTILATORI	FAN PRESSURE SWITCH	std
B5	TRASDUTTORE ALTA PRESSIONE	HIGH PRESSURE TRASDUCER	optional (included in the optional RV)
RV	REGOLATORE DI VELOCITA' VENTILATORI A INVERTER	INVERTER FAN SPEED REGULATOR	optional
SCR	VALVOLA DI CARICO SCHRADER	CHARGE VALVE (SCHRADER)	std
Y4	VALVOLA SOLENOIDE LINEA DEL LIQUIDO	LIQUID LINE SOLENOID VALVE	std
FLT	FILTRO DISIDRATATORE	DEHYDRATING FILTER	std
LIQ	SPIA DI FLUSSO / INDICATORE DI LIQUIDO	LIQUID INDICATOR / SIGHT GLASS FOR LIQUID LINE	std
VTS	VALVOLA DI ESPANSIONE TERMOSTATICA	THERMOSTATIC EXPANSION VALVE	std
SCA	SCAMBIATORE DI CALORE AD ACQUA (EVAPORATORE APIASTRE)	WATER HEAT EXCHANGER (BRAZED PLATE EVAPORATOR)	std
CSV	VALVOLA DI INTERCETTAZIONE COMPRESSORI	COMPRESSORS SHUT OFF VALVE	optional
SCR	VALVOLA DI CARICO SCHRADER	CHARGE VALVE (SCHRADER)	std
LP1	PRESSOSTATO BASSA PRESSIONE	LOW PRESSURE SWITCH	optional
LPG	MANOMETRO BASSA PRESSIONE	LOW PRESSURE GAUGE	optional

	CIRCUITO FRIGORIFERO ALTA PRESSIONE / HIGH PRESSURE REFRIGERANT CIRCUIT
	CIRCUITO FRIGORIFERO BASSA PRESSIONE / LOW PRESSURE REFRIGERANT CIRCUIT
	LINEA DEI EQUALIZZAZIONE DELL'OLIO / EQUALISATION LINE OF OIL

LEGENDA /
LEGEND

Scala-Scale	Data-Date 09/10/2013	Dis.to-Drawn A.F.	Ver.-Version		
Peso-Weight Kg	Materiali-Materials				
Denominazione-Denomination CFT.061÷100				DIS.-DRAW N.	SFI-CFT-061ST01
Particolare-Detail SCHEMA FRIGORIF./IDRAULICO HYDRAULIC/REFRIGERATING DIAGRAM				REVISIONE	02 - 30/09/2016 T.F.
FOGLIO/SHEET 4/4				PROGRAM. N.	