

N°6 holes for floor mounted (ATS/ATV OPTION)

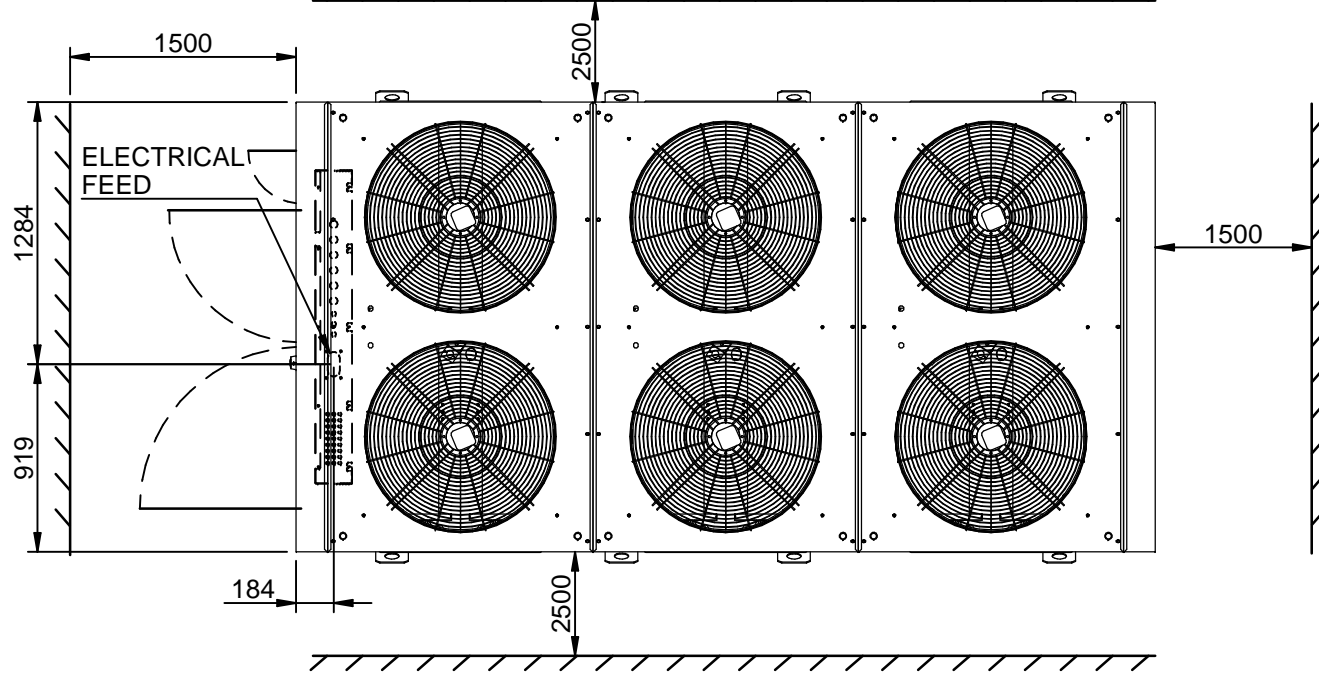

LIFTING AND CARRIAGE PRECAUTIONS

- Check the weight on the CE label to select appropriate lift equipment .
- Before lifting the unit make sure that the external panel is firmly fixed in place.
- To use only lifting points provided.
- The chains or slings must be of equal length.
- To use a spread-bar to avoid damage to the unit.
- The movement must be performed with caution and avoid abrupt movements.
- Never move the unit on rollers.
- Never lift the unit using a fork-lift.



LEGEND

HPG	High pressure gauge (Opt)
LPG	Low pressure gauge (Opt)
ATS	Spring type antivibrant mounting (Opt)
ATV	Rubber type antivibrant mounting (Opt)

MOD.	EMPTY WEIGHT	OPERATING WEIGHT	HYDRAULIC CONNECTIONS
SBS.330/F6	2800 kg	2900 kg	DN125
SBS.380	2850 kg	2950 kg	DN150
SBS.430	3150 kg	3270 kg	DN150
SBS.470	3210 kg	3350 kg	DN150

Scala-Scale	Data-Date	Dis.to-Drawn	N°Pezzi
	15/09/16	B.P.	
Peso-Weight Kg.	Materiali-Materials		
Denominazione-Denomination			
WATER CHILLERS mod. SBS.380÷470/CS.ST.NT.NP.			
Particolare-Detail			
Overall dimension - Lift Instruction			
REFRIGERANT R410a			



DIS.-DRAW N.	DIM-SBS-380ST01
Rev.	01 - B.P. - 08/08/18
PROGRAM.N.	