

**LEGEND**

HPG	High pressure gauge
LPG	Low pressure gauge
MW	Water pressure gauge
RM	Manual water filling cap
SFAS	Tank manual air vent
SFA	Manual air vent
VSCS	Tank water drain valve
ATS	Spring type antivibrant mounting ( Opt )
ATV	Rubber type antivibrant mounting ( Opt )

**LIFTING AND CARRIAGE PRECAUTIONS**

- Check the weight on the CE label to select appropriate lift equipment .
- Before lifting the unit make sure that the external panel is firmly fixed in place.
- To use only lifting points provided.
- The chains or slings must be of equal length.
- To use a spread-bar to avoid damage to the unit.
- The movement must be performed with caution and avoid abrupt movements.
- Never move the unit on rollers.
- Never lift the unit using a fork-lift.

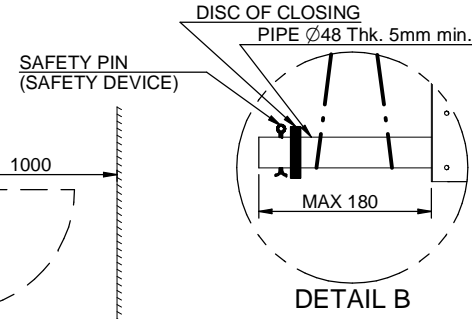
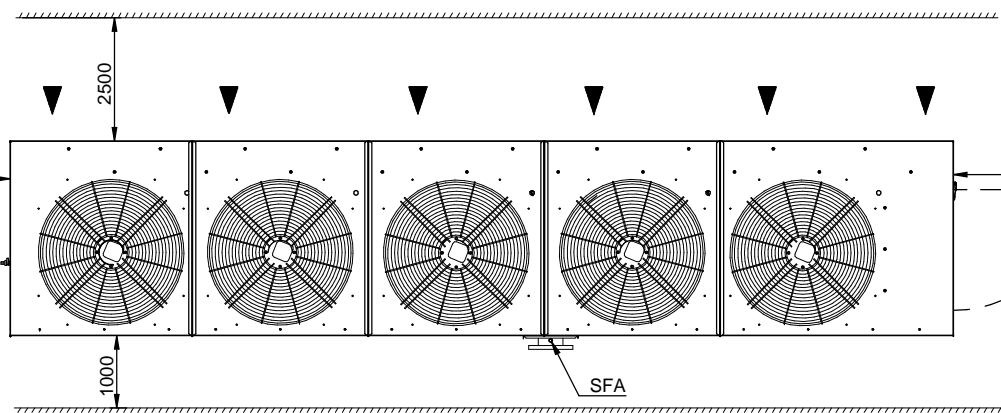

MOD.	EMPTY WEIGHT	OPERATING WEIGHT
ENR.230	2105 kg	2660 kg
ENR.280	2240 kg	2800 kg
ENR.340	2415 kg	2995 kg

Scala-Scale	Data-Date	Dis.to-Drawn	N°Pezzi
	09/07/13	B.C.	
Peso-Weight Kg.	Materiali-Materials		
Denominazione-Denomination			
WATER CHILLERS mod. ENR.230÷340/CS.ST.T.WP.			
Particolare-Detail			
Overall dimension - Lift Instruction			
REFRIGERANT R410a			

**HITEMA®**

DIS-DRAW N.	DIM-ENR-230ST01
Rev.	02 - B.C. - 11/01/17
PROGRAM.N.	

