

N°9 holes Ø23mm for floor mounted ATS/ATV (OPT)

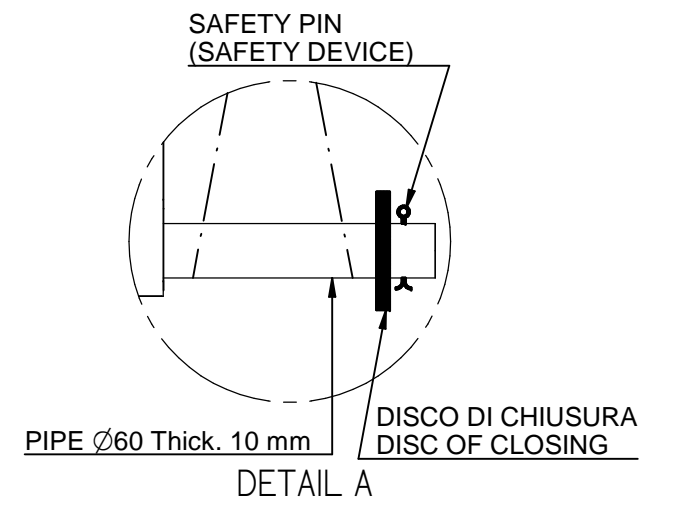
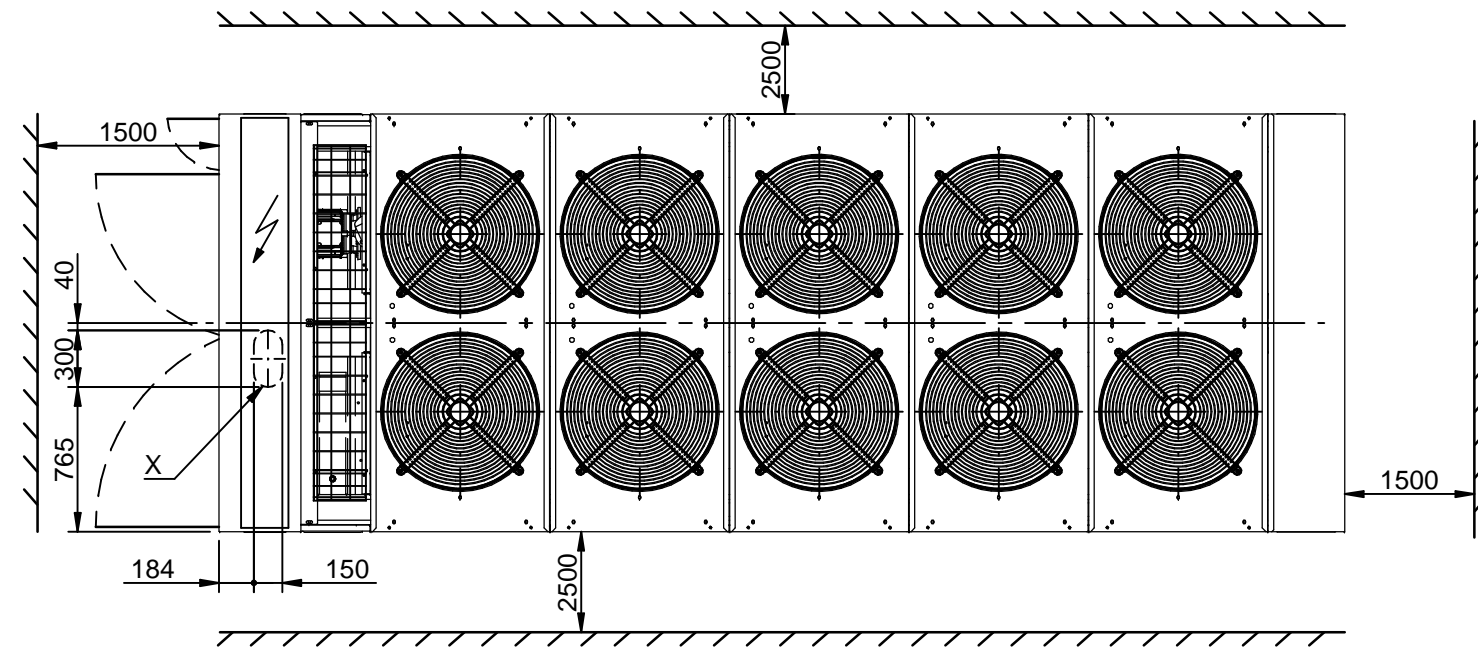

LEGEND

HPG	High pressure gauge
LPG	Low pressure gauge
ATS	Spring type antivibrant mounting (Opt)
ATV	Rubber type antivibrant mounting (Opt)

MOD.	EMPTY WEIGHT	OPERATING WEIGHT	HYDRAULIC CONNECTIONS
EET.650	5600 kg	5820 kg	DN150
EET.700	5850 kg	6100 kg	DN150

LIFTING AND CARRIAGE PRECAUTIONS

- Check the weight on the CE label to select appropriate lift equipment .
- Before lifting the unit make sure that the external panel is firmly fixed in place.
- To use only lifting points provided.
- The chains or slings must be of equal length.
- To use a spread-bar to avoid damage to the unit.
- The movement must be performed with caution and avoid abrupt movements.
- Never move the unit on rollers.
- Never lift the unit using a fork-lift.

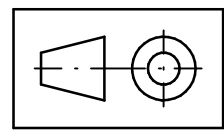
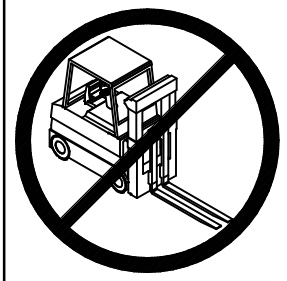

X: ELECTRIC FEED HOLE

Scala-Scale	Data-Date	Dis.to-Drawn	N°Pezzi
	30/03/15	B.P.	
Peso-Weight Kg.	Materiali-Materials		
Denominazione-Denomination			
WATER CHILLERS mod. EET.650÷700/CS.ST.NT.NP...			
Particolare-Detail			
Overall dimension - Lift Instruction			
FRAME 5950x2210x2450			

HITEMA ®	
DIS.-DRAW N.	DIM-EET-650ST01
Rev.	01-01/07/2015-M.S.
PROGRAM.N.	