

N°9 holes Ø23mm
for floor mounted
ATS/ATV (OPT)

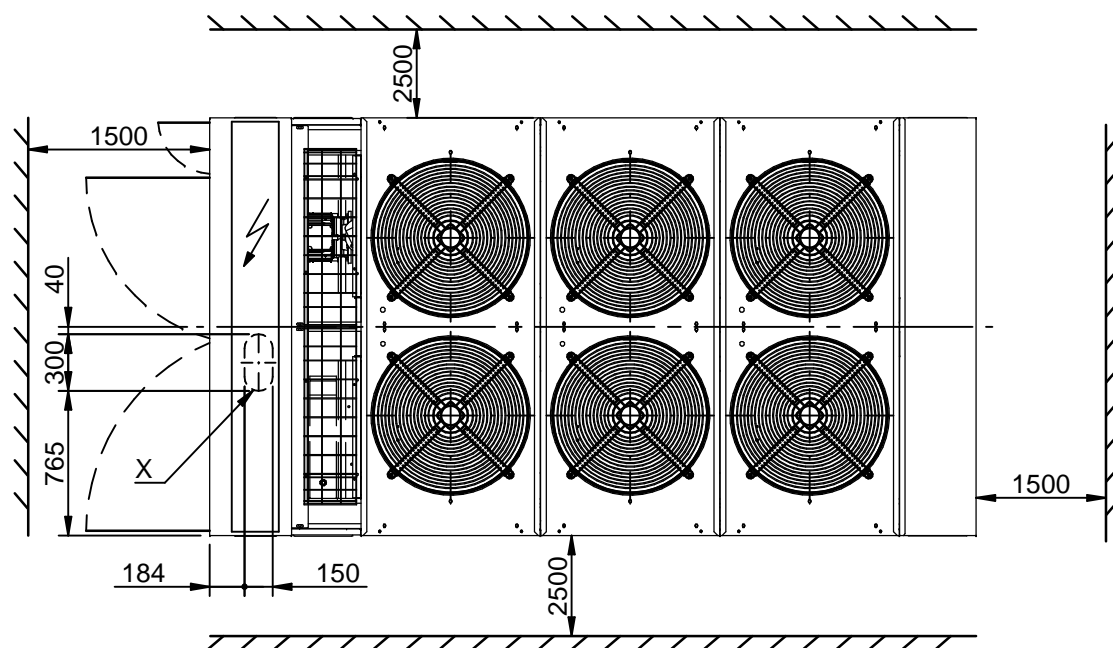

SAFETY PIN
(SAFETY DEVICE)

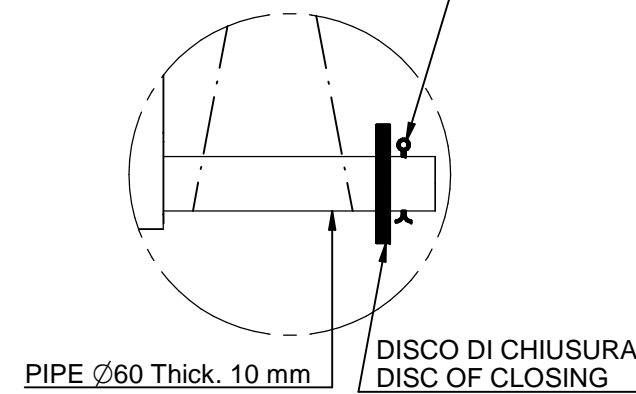

LEGEND

HPG	High pressure gauge
LPG	Low pressure gauge
ATS	Spring type antivibrant mounting (Opt)
ATV	Rubber type antivibrant mounting (Opt)

MOD.	EMPTY WEIGHT	OPERATING WEIGHT	HYDRAULIC CONNECTIONS
EET.300	3900 kg	4060 kg	DN125
EET.350	4200 kg	4370 kg	DN125
EET.400	4300 kg	4480 kg	DN125

LIFTING AND CARRIAGE PRECAUTIONS

- Check the weight on the CE label to select appropriate lift equipment .
- Before lifting the unit make sure that the external panel is firmly fixed in place.
- To use only lifting points provided.
- The chains or slings must be of equal length.
- To use a spread-bar to avoid damage to the unit.
- The movement must be performed with caution and avoid abrupt movements.
- Never move the unit on rollers.
- Never lift the unit using a fork-lift.

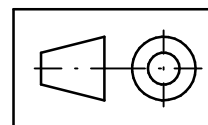

X: ELECTRIC FEED HOLE

Scala-Scale	Data-Date	Dis.to-Drawn	N°Pezzi	HITEMA®
	30/03/15	B.P.		
Peso-Weight Kg.	Materiali-Materials			
Denominazione-Denomination				DIS.-DRAW N.
WATER CHILLERS mod. EET.300÷400/CS.ST.NT.NP...				DIM-EET-300ST01
Particolare-Detail				Rev.
Overall dimension - Lift Instruction				01-01/07/2015-M.S.
FRAME 4050x2210x2450				PROGRAM.N.