

N°9 holes Ø23mm
for floor mounted
ATS/ATV (OPT)

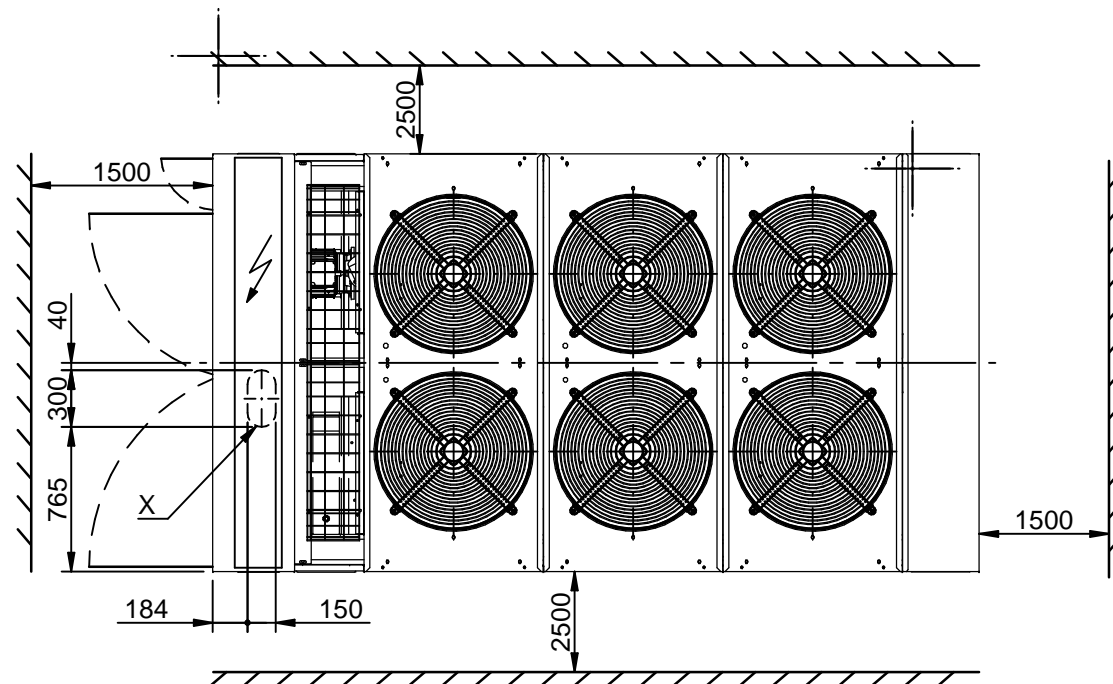

SAFETY PIN
(SAFETY DEVICE)

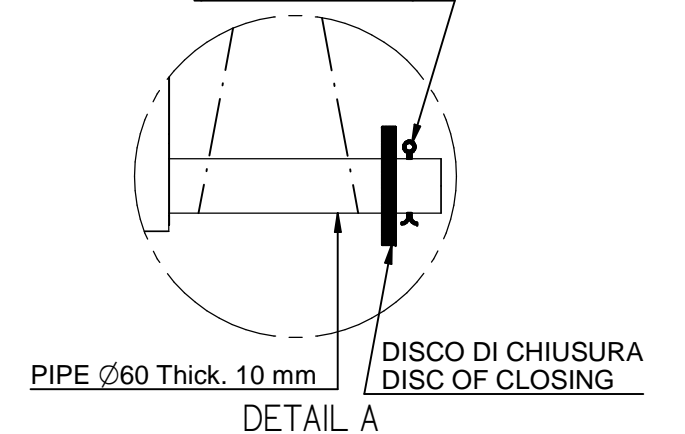

LEGEND

HPG	High pressure gauge
LPG	Low pressure gauge
ATS	Spring type antivibrant mounting (Opt)
ATV	Rubber type antivibrant mounting (Opt)

MOD.	EMPTY WEIGHT	OPERATING WEIGHT	HYDRAULIC CONNECTIONS
EEF.210	3700 kg	3850 kg	DN125
EEF.250	3800 kg	3950 kg	DN125
EEF.300	4000 kg	4160 kg	DN125
EEF.350	4100 kg	4270 kg	DN125

LIFTING AND CARRIAGE PRECAUTIONS

- Check the weight on the CE label to select appropriate lift equipment .
- Before lifting the unit make sure that the external panel is firmly fixed in place.
- To use only lifting points provided.
- The chains or slings must be of equal length.
- To use a spread-bar to avoid damage to the unit.
- The movement must be performed with caution and avoid abrupt movements.
- Never move the unit on rollers.
- Never lift the unit using a fork-lift.

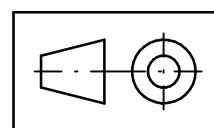

X: ELECTRIC FEED HOLE

Scala-Scale	Data-Date	Dis.to-Drawn	N°Pezzi
	30/03/15	B.P.	
Peso-Weight Kg.	Materiali-Materials		
Denominazione-Denomination			
WATER CHILLERS mod. EEF.210÷350/CS.ST.NT.NP...			
Particolare-Detail			
Overall dimension - Lift Instruction			
FRAME 4050x2210x2450			
DIS.-DRAW N.		DIM-EEF-210ST01	
Rev.		01-01/07/2015-M.S.	
PROGRAM.N.			

